

LEO24T

Technical data*

PERFORMANCE

Working height, max.	24,00 m
Platform height, max.	22,00 m
Horizontal outreach, max. (100 kg)	14,00 m
Horizontal outreach, max. (250 kg)	12,00 m
Platform capacity, max.	250 kg
Jib, movable	180°
Platform rotatable	180°
Turntable rotation, max.	450°
To be jacked up on ground slope of	16,7° / 30,0 %
Track drive, height- & width adjustable	21 cm / 42 cm
Gradeability, max.	16,7° / 30,0 %
Slope angle, max.	15,5° / 27,0 %
Travel speed, max.	2,5 km/h

MEASUREMENTS*

Platform height (A)	1,10 m
Platform length (B)	1,40 m
Platform width (C)	0,70 m
Length (D)	6,95 m
Length without platform (E)	6,70 m
Height (F)	1,99 m
Width, min. (G)	0,89 m
Ground clearance, max. (H)	0,26 m
Track (length x width) (I)	1,50 m x 0,23 m

Stabilisation

Wide: Length (J) x width (K)	4,90 m x 4,70 m
Narrow: Length (L) x width (M)	6,50 m x 2,99 m
Left or right narrow: Width (N)	3,90 m
Front or back narrow: Length (O)	5,68 m
Outrigger plate Ø	0,18 m

WEIGHT*

Total weight	2990 kg
Live load in travelling position	3,76 kN/m ²
Live load in working position	1,38 kN/m ²
Point load per outrigger plate, max.	22,50 kN

POWER SOURCES

Standard power sources

- Electric motor 230 V, 12,9 A, 2,2 kW
- Combustion engine (Diesel) Kubota Z602 (10,8kW/14,7hp)
- Fuel tank capacity (Diesel engine) 11,50 l

Optional power sources

- Battery drive (AGM) 48 V

POWER SUPPLY

Electric current, max.	Country specific, on request
------------------------	------------------------------

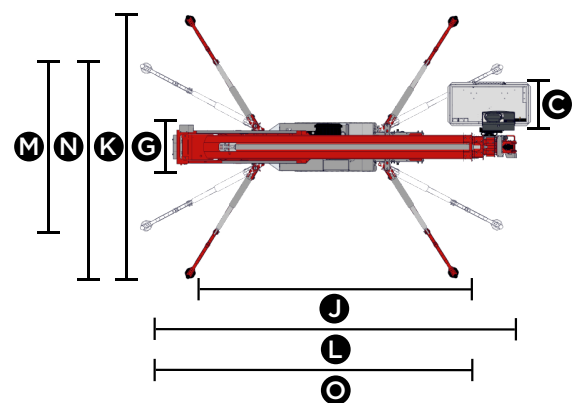
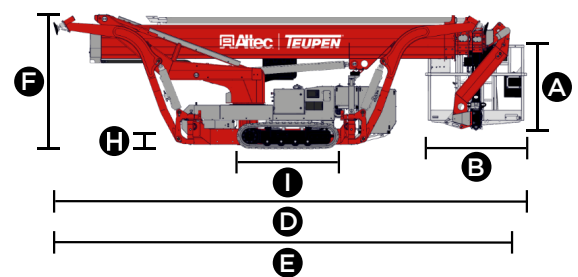
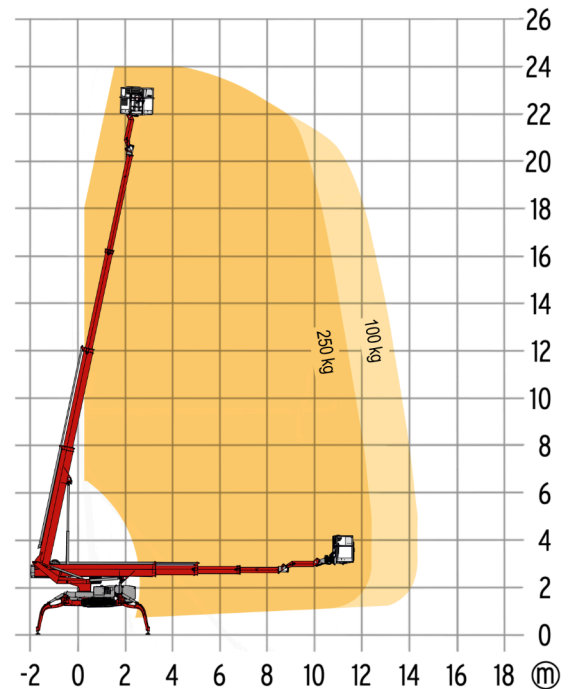

STANDARDS

Harmonised standard DIN EN 280:2016

The technical data may deviate +/- 3% from the specified values.
 * Preliminary technical data - subject to change.
 ** Weight and dimensions may vary depending on options and accessories.

Equipment

CHASSIS

- Powerful track drive with hydraulic braking system
- Precise manoeuvring via sensitive remote control
- White indoor non-marking rubber tracks, with less tread depth the profiles enables smooth travelling
- Hydraulically height- and width adjustable crawler track drive

STABILISATION

- Electrohydraulic stabilisation with automatic levelling and ground pressure sensor system
- Variable outrigger system
 - wide supported
 - narrowly supported
 - left or right supported
 - front or back supported
- Wear resistant, anti-friction outrigger pads

BOOM SYSTEM

- Telescopic booms made of high-strength steel
- All functions available via radio remote control
- 180° platform rotation for additional flexibility
- Jib movable by 180°
- Coming home function - automatic return of the boom into transport position
- Platform changing system
- Robust, lockable control panel

POWER

- Electric motor (country-specific 1-phase)
- Diesel engine Kubota Z602 (10,8 kW / 14,7 hp)
- Start-stop device for combustion engine via radio control

PRODUCTIVITY, SAFETY, QUALITY

- Power socket in the platform (230 V / 16 A)
- USB socket in the control panel (5 V)
- Power socket in the control panel (country-specific 1-phase)
- Drive operation without platform possible
- Lockable storage box
- 4x Sliding pad (700 x 220 x 60 mm)
- Treecare package light, including 4 Covers on piston rod (outriggers)
- Protected, internal power track for platform
- Hydraulic system filled with biodegradable hydraulic oil
- High quality paint in RAL 3020 (red)
 - Hydraulic cylinders in RAL 9006 (white aluminium)
 - Engine unit & component support in RAL 9006 (white aluminium)
- Unlockable check valved located directly on hydraulic cylinders
- Hydraulic system protected by pressure relief valves
- Hydraulic tank, emergency control, connecting cables and hoses are mounted protected
- Colour display in the control panel
- Additional colour display in the chassis
- TEUPEN Fuzzy V control technology with new intuitive operating concept

OPTIONS**

- Battery drive (AGM) 48 V
- Custom paintwork, one colour, according to RAL scheme***
- Custom paintwork, two colours, according to RAL scheme***
- Flashlights on the outrigger (12 V)
- Flashlights on the turntable (12 V)
- Flashlights on the platform (12 V)
- 2 LED headlights (engine unit)
- 2 LED headlights (turntable)
- 1 LED headlight (platform)
- Platform ladder monitoring system with boom function cut-off
- Copper strips, pivot point incl. ground spike
- Additional connection in the platform
- TOPS (TEUPEN Operator Protection)
- Additional hydraulic drive with electric pump (12V)
- Storage frame for sliding pads, lockable
- Snap hook, boom tubes

ACCESSORIES

- Safety harness
- Track mat (2000 x 800 x 15 mm)
- Lifting device (300 kg capacity)

TRANSPORT

- Tandem-trailer (Alu)
 - max. permissible weight 3,5 t
 - Net weight 475 kg
 - Payload 3025 kg
- Tandem low platform trailer (Alu) - with loose ramps
 - max. permissible weight 3,5 t
 - Net weight 500 kg
 - Payload 3000 kg

CONTACT

TEUPEN Maschinenbau GmbH
Marie-Curie-Str. 13
48599 Gronau, Germany

Phone +49 2562 8161 0
Fax +49 2562 8161 888
E-Mail mail@teupen.com

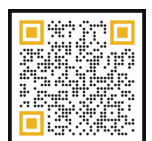

2026-A_EN

* Preliminary technical data - subject to change.
** Weight and measurements may vary depending on options and accessories.
*** Except metallic coatings, signal- or special colours.

Product specifications are subject to change without notice or obligation. Photographs and drawings in this document are for illustrative purposes only. Refer to the appropriate Operator's Manual for instructions on the proper use of this equipment. Failure to follow the appropriate Operator's Manual when using our equipment or to otherwise act irresponsibly may result in serious injury or death. The only warranty applicable to our equipment is the standard written warranty applicable to the particular product and sale and we make no other warranty, expressed or implied. Products and services listed may be trademarks, service marks or trade-names of TEUPEN Maschinenbau GmbH and/or its corporate entities in the U.S.A. and many other countries. "TEUPEN", "Access redefined" and "LEO Series" are registered Trademarks of Teupen GmbH in the United States of America and many other countries. © 2025 TEUPEN Maschinenbau GmbH.