

LEO34GTplus

Technical data

PERFORMANCE

Working height, max.	34,10 m
Platform height, max.	32,10 m
Horizontal outreach, max. (140 kg)	19,90 m
Horizontal outreach, max. (300 kg)	18,90 m
Horizontal outreach, max. (400 kg)	18,00 m
Negative reach, max.	9,20 m
Up and over clearance, max.	21,00 m
Platform capacity, max.	400 kg
Jib, movable	200°
Platform rotatable	2 x 220°
Turntable rotation, max.	450°
To be jacked up on ground slope of	16,7° / 30,0 %
Track drive, height- & width adjustable	23 cm / 12 cm
Gradeability, max.	16,7° / 30,0 %
Slope angle, max.	16,7° / 30,0 %
Travel speed, max.	3,0 km/h

MEASUREMENTS*

Platform height (A)	1,10 m
Platform length (B)	1,50 m
Platform width (C)	0,80 m
Length (D)	7,85 m
Length without platform (E)	7,00 m
Height (F)	1,99 m
Width, min. (G)	1,59 m
Ground clearance, max. (H)	0,40 m
Track (length x width) (I)	2,12 m x 0,30 m

Stabilisation

Wide: Length (J) x width (K)	5,31 m x 5,20 m
Narrow: Length (L) x width (M)	7,30 m x 2,70 m
Left or right narrow: Width (N)	4,00 m
Outrigger plate (length x width)	0,50 m x 0,22 m

WEIGHT*

Total weight	8210 kg
Live load in travelling position	6,20 kN/m ²
Live load in working position	3,06 kN/m ²
Point load per outrigger plate, max.	57,70 kN

POWER SOURCES

Standard power sources

• Electric motor	Country specific 3-phases
• Combustion engine (Diesel)	Kubota D1305 (18kW/24,47hp)
• Fuel tank capacity (Diesel engine)	32,00 l

POWER SUPPLY

Electric current, max.	Country specific, on request
------------------------	------------------------------

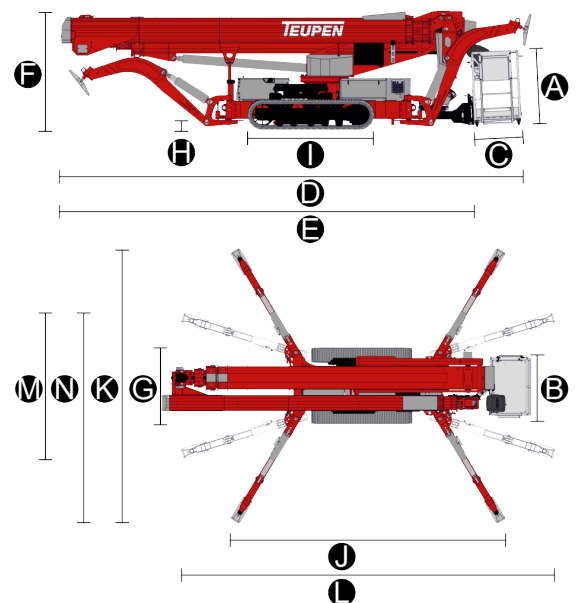
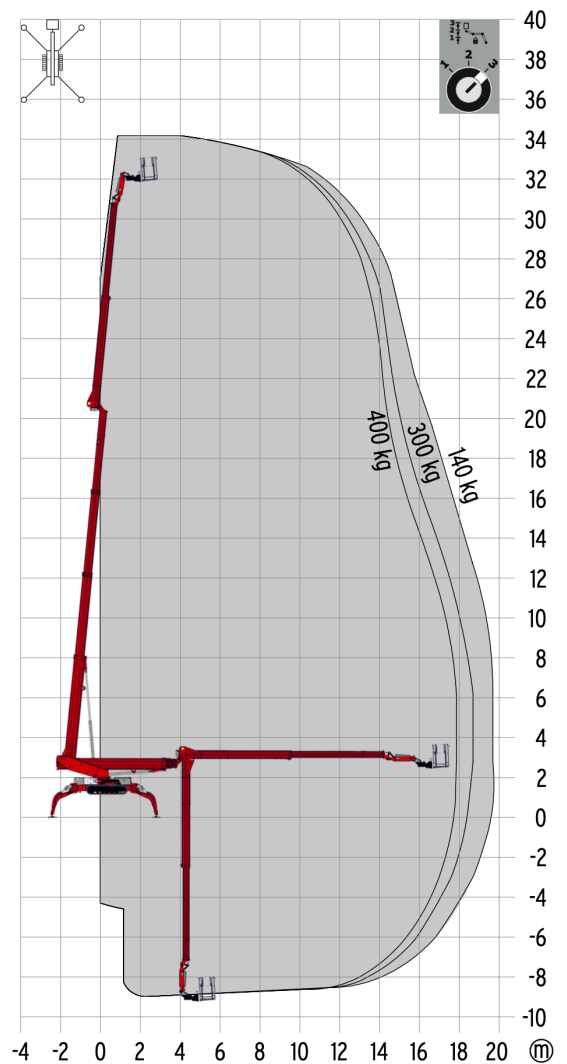

STANDARDS

Harmonised standard DIN EN 280:2016

The technical data may deviate +/- 3% from the specified values.
* Weight and dimensions may vary depending on options and accessories.

Equipment

CHASSIS

- Powerful track drive with hydraulic braking system
- Precise manoeuvring via sensitive remote control
- White, non-marking rubber tracks with specially arranged profile for optimal grip
- Hydraulically height- and width adjustable crawler track drive

STABILISATION

- Electrohydraulic stabilisation with automatic levelling and ground pressure sensor system
- Variable outrigger system with one side or both sides narrow setup option
- Outrigger pads, steel

BOOM SYSTEM

- Telescopic lower and upper boom
- All functions available via radio remote control
- Robust, lockable control panel
- 2 x 220° platform rotation for additional flexibility
- Jib movable by 200°
- Platform changing system
- Coming home and memory function - can be stored for any point on the work diagram and the point can be accessed once more at the touch of a button
- Radio control with display, two-line
- Height cut-off for boom system, 2 set points
- Horizontal outreach, selectable

POWER

- Electric motor (country specific 3-phases)
- Diesel engine Kubota D1305 (18,0 kW / 24,47 hp)
- Start-stop device for combustion engine in the platform

PRODUCTIVITY, SAFETY, QUALITY

- Hydraulic emergency lowering via electric pump
- Additional hydraulic drive for boom recovery via platform control
- Power socket in the platform (country-specific 1-phases)
- Ultrasonic sensors platform
- 2 LED headlights (drive unit)
- Detachable platform
- Drive operation without platform possible
- Lockable storage box
- Protected, internal power track for platform
- Hydraulic system filled with biodegradable hydraulic oil
- High quality paint in RAL 3020 (red)
 - Hydraulic cylinders in RAL 9006 (white aluminium)
 - Engine unit & component support in RAL 9006 (white aluminium)
- Unlockable check valve located directly on hydraulic cylinders
- Hydraulic system protected by pressure relief valves
- Display in the control panel
- Additional display in the control box
- Hour meter

OPTIONS*

- Battery drive (lithium) 96 V
- Custom paintwork, one colour, according to RAL scheme**
- Custom paintwork, two colours, according to RAL scheme**
- Storage frame for sliding pads, lockable
- Hydraulic generator
- Tree package light, including
 - 4 covers, piston rod (outrigger)
- Tree package, including
 - Tree package light
 - Cover over component tray
- Flashlights on the outrigger (12 V or 24 V)
- Flashlights on the turntable (12 V or 24 V)
- Flashlights on the platform (12 V or 24 V)
- 2 LED headlights (turntable)
- 1 LED headlight (platform)
- Platform ladder monitoring system with boom function cut-off
- Copper strips, pivot point
- Additional connections on the platform
- TOPS (TEUPEN Operator Protection) for platform sizes 900x800 or 1200x800
- TOPS (TEUPEN Operator Protection) for platform sizes 1500x800 or 2000x800
- Platform 900 x 800
- Platform 1200 x 800
- Platform 2000 x 800
- Handrail protection for platform for sizes 900x800, 1200x800, 1500x800, 2000x800

ACCESSORIES

- Safety harness
- Sliding pad (900 x 300 x 80 mm)
- Track mat (2000 x 800 x 15 mm)
- Lifting device (450 kg capacity)
- Additional platform 900 x 800
- Additional platform 1200 x 800
- Additional platform 2000 x 800

CONTACT

TEUPEN Maschinenbau GmbH
Marie-Curie-Str. 13
48599 Gronau, Germany

Phone +49 2562 8161 0
Fax +49 2562 8161 888
E-Mail mail@teupen.com

* Weight and measurements may vary depending on options and accessories.
** Except metallic coatings, signal- or special colours.



2026-A_EN

Product specifications are subject to change without notice or obligation. Photographs and drawings in this document are for illustrative purposes only. Refer to the appropriate Operator's Manual for instructions on the proper use of this equipment. Failure to follow the appropriate Operator's Manual when using our equipment or to otherwise act irresponsibly may result in serious injury or death. The only warranty applicable to our equipment is the standard written warranty applicable to the particular product and sale and we make no other warranty, expressed or implied. Products and services listed may be trademarks, service marks or trade-names of TEUPEN Maschinenbau GmbH and/or its corporate entities in the U.S.A. and many other countries. "TEUPEN", "Access redefined" and "LEO Series" are registered Trademarks of Teupen GmbH in the United States of America and many other countries. © 2025 TEUPEN Maschinenbau GmbH.